

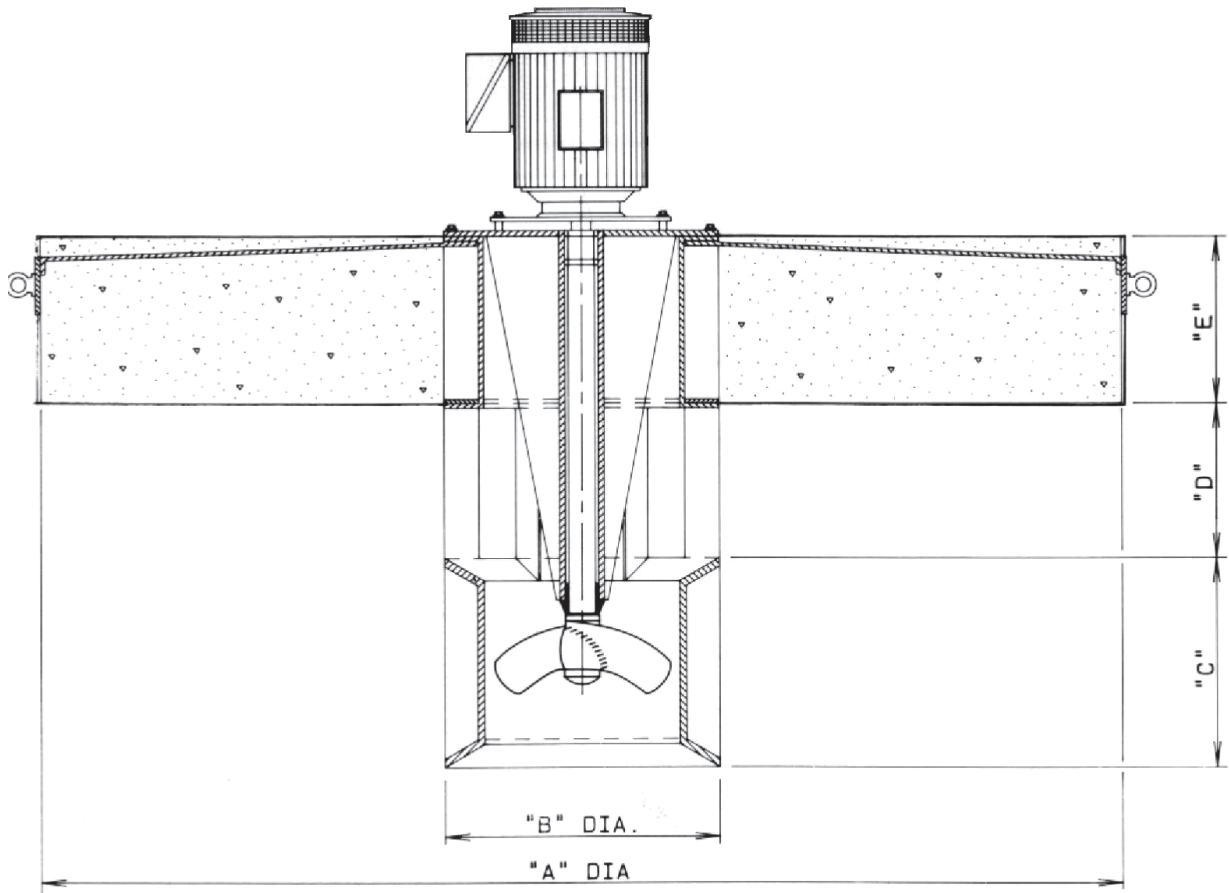

**SKELLERUP**

**CONTAINMENT SYSTEMS**

A Division of Viking Group Limited



## 1200 RPM Floating Mixer

| Mixer Size | 'HP' | 'A'   | 'B'  | 'C'  | 'D'  | 'E'  |
|------------|------|-------|------|------|------|------|
| FM1205     | 5    | 182.8 | 39.7 | 25.4 | 20.3 | 33.2 |
| FM1207     | 7.5  | 182.8 | 41.9 | 25.4 | 20.3 | 33.2 |
| FM1210     | 10   | 182.8 | 40.0 | 25.4 | 20.3 | 33.2 |
| FM1215     | 15   | 289.5 | 57.7 | 30.4 | 25.4 | 38.1 |
| FM1220     | 20   | 213.3 | 57.7 | 30.4 | 25.4 | 38.1 |
| FM1225     | 25   | 243.8 | 62.2 | 30.4 | 25.4 | 38.1 |
| FM1230     | 30   | 243.8 | 62.2 | 30.4 | 25.4 | 38.1 |
| FM1240     | 40   | 284.4 | 62.2 | 38.1 | 30.4 | 45.7 |
| FM1250     | 50   | 284.4 | 64.7 | 38.1 | 30.4 | 45.7 |
| FM1260     | 60   | 284.4 | 64.7 | 38.1 | 30.4 | 45.7 |

When reliability matters