

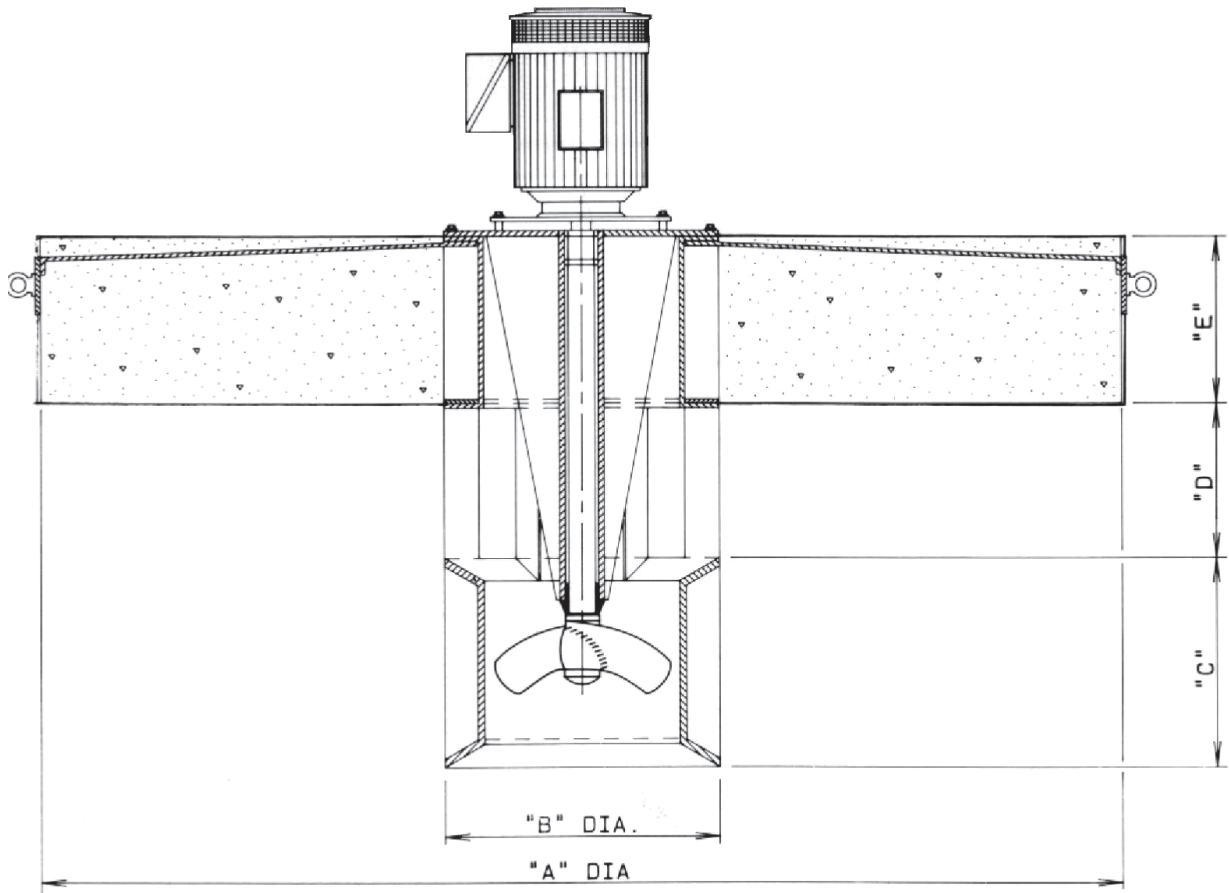

SKELLERUP

CONTAINMENT SYSTEMS

A Division of Viking Group Limited



1800 RPM Floating Mixer

Mixer Size	'HP'	'A'	'B'	'C'	'D'	'E'
FM1801	1	152.4	30.4	20.3	15.2	30.4
FM1802	2	152.4	31.7	20.3	15.2	30.4
FM1803	3	152.4	31.7	20.3	15.2	30.4
FM1805	5	152.4	32.0	20.3	15.2	30.4
FM1807	7.5	177.8	35.5	25.4	20.3	35.5
FM1810	10	177.8	41.9	25.4	20.3	35.5
FM1815	15	182.8	47.6	30.4	25.4	40.6
FM1820	20	182.8	47.6	30.4	25.4	40.6

Floating Mixers 1800 Series

When reliability matters